



SEWER CONNECTION APPLICATION

Instructions and Procedures



Rev. 2-7-2020

1. A complete application with plans and specifications must be submitted to Michael Finn, DPW Dispatcher, by email (watersewerapps@cityofportsmouth.com) or delivered to the DPW office at 680 Peverly Hill Road. The application, plans and specifications will be reviewed for completeness by staff and must be completed at least 2 weeks in advance of anticipated service inspection. Property owner is responsible for the sewer lateral from the building to the main including the connection.
2. If application and materials are deemed incomplete, the applicant will be notified and the application will be placed on hold. If materials are deemed complete, the applicant will be directed to contact Jim Tow, General Foreman, to schedule a meeting.
3. Once the applicant has met with Jim Tow and paid all fees in full, the applicant can schedule an inspection. The area of work must be exposed and uncovered for City staff to inspect.
4. The Public Works Department reserves the right to refuse applications which do not meet these minimum requirements. The Public Works Department may also require additional information to illustrate the scope of the project.
5. The Applicant is encouraged to consider the following when completing the application:
 - Complete application using Adobe Acrobat Reader
 - Plans and specifications must be in PDF format if submitted electronically
 - Provide neat and clearly legible plans and copies
 - Use of color or highlights is encouraged in order to identify pertinent areas on plans

City of Portsmouth Sewer Installation Guidelines

The following guideline will illustrate the City's requirements for sewer installation.

1. All sewer pipe and fittings will be PVC type SDR-35 with rubber gasketed joints. **NO** glued fittings are allowed for outside plumbing.
2. Rubber "Fernco" style couplings will only be allowed for connecting to clay or asbestos "Transite" pipe. PVC to PVC or schedule 40 pipe must always use solid sleeve couplings.



3. All sewer pipe will have no less than 6" of 3/4" crushed stone base to at least the spring line of the pipe. The base stone will be laid before the pipe. From the spring line of the pipe to 1 foot over the pipe may be 3/4" stone or sand followed by miscellaneous clean fill and 12" of crushed gravel. Pavement, if applicable, shall be restored to its original depth.

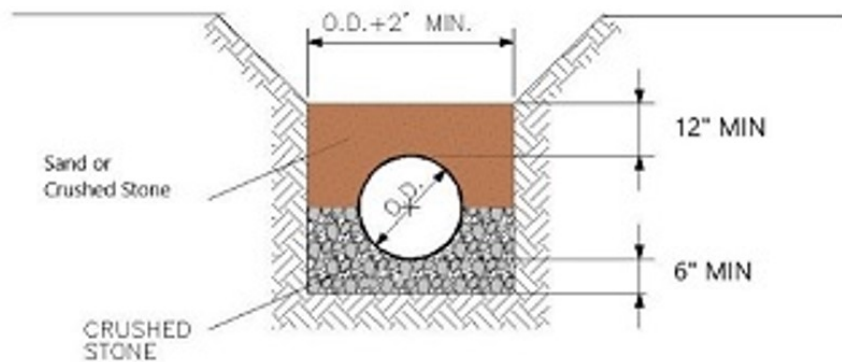

PIPE BEDDING AND HAUNCHING DETAILS

4. The foundation penetration should be schedule 40 PVC and should extend no more than 5 feet outside the wall. The seal shall be flexible, such as a Linkseal or a pipe sleeve with a Fernco type coupling.

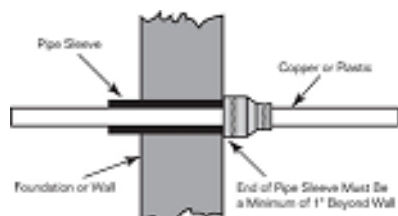



CITY OF PORTSMOUTH
 DEPARTMENT OF PUBLIC WORKS
 680 PEVERLY HILL ROAD, PORTSMOUTH NH 03801
 (603) 427-1530



Sewer Connection Application

To the City of Portsmouth:

Applicant, Owner, etc. Print Name

The undersigned, being the
 Street Number Street Name

of the property located at

does hereby request a permit to install and connect a sewer service to the

(Residence, Commercial Building, etc.)

at said location.

1. Contractor Information:

Contractor's Company Name	Contractor's Address	Phone Number
---------------------------	----------------------	--------------

Contact Person	Email	Drain Layers Number
----------------	-------	---------------------

2. Plans and specifications for the proposed sewer connection are attached as Exhibit "A".

In consideration of the granting of this permit, the undersigned agrees:

1. To accept and abide by all provisions of the Sewer Ordinance of the City of Portsmouth, and of all other pertinent ordinances or regulations that may be adopted in the future.
2. To maintain the building sewer at no expense to the City.
3. To contact the Utility Department at 427-1530 to request an inspection and connection to the public sewer system, but before any portion of the work is covered.

By selecting this box, the undersigned acknowledges to have read the application instructions and confirms all information provided is correct and true.

Applicant's Signature	Applicant's Address
-----------------------	---------------------

Applicant's Name	Date
------------------	------

City Representative	Notes
---------------------	-------